

BH3-V Peristaltic Dosing Pumps

Overview

The B series are a range of peristaltic pumps fixed and variable flow rates designed for discontinuous use. Both the B Series and BH Series are perfect for smaller dosing systems that require small amounts of chemical addition in short periods of time.



BH3-V Dosing Pump

Technical Features

- **Flow Rate** 100 L/H maximum
- **Maximum Pressure** 1.5 Bar
- **Power Supply** 90 – 260 V standard
- **Tubing** Available in Santoprene, Silocone, Norprene or tygon
- **Flow Rate Adjustment** 10 – 100%
- **Accessories** Supplied with metre suction/discharge tubing (injection valve or foot filter not included)

Dimensions (in mm)

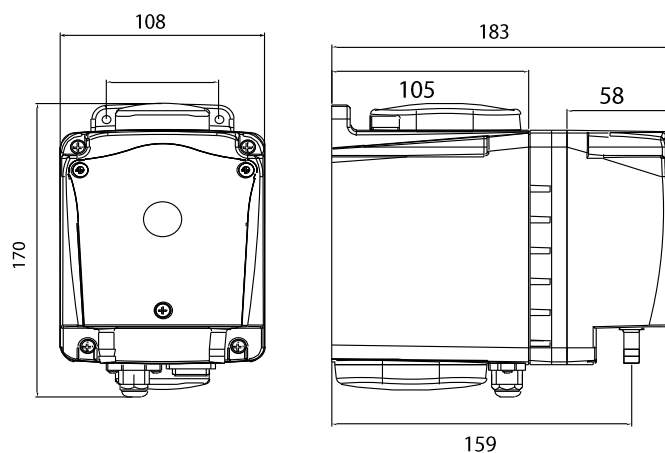

BH3-V Peristaltic Dosing Pumps

Technical Features

Version	Flow rate	Pressure	Net Weight	Absorbed power	Rotation speed	Tube size	Dimensions (In mm)
	l/h (US Gal/h)	bar (psi)	Kg	Watt	rpm	mm	Height Width Depth
1000	100 (26.41)	1,5 (21)	1,50	25	150	9.6 x 15.9	170 108 183