

BD Series Motor Driven Diaphragm Pump

OVERVIEW

The BD series is a versatile and robust mechanical diaphragm pump dosing pump for chemical dosing. Extensive build options permit great customisability to maximise economy and practicality.

All pumps have manual stroke length adjustment as standard. Optional automatic stroke length adjustment with a 4-20 mA signal.

The pump is encased in grey anodized aluminium finished with an anti-acid paint.

Can be built with an ATEX Zone 2 rated motor.



BD motor pump with AISI pump head

TECHNICAL FEATURES

- Flow Rate 79 - 535 L/H
- Maximum Pressure 12 Bar (low flow rate models), 2.5 bar (highest flow rate models).
- Motor Options Single Phase, Three Phase, optional ATEX Zone 2 compatibility, optional self-ventilated motor. Accepts 230 – 400 V input at 50 Hz, single phase motors either 230 V or 110 V.
- Inverter Control Yes. Expert installation only. Requires self-ventilated motor.
- Pump Head PVC, AISI or PVDF
- Seal Material FPM, EPDM & NBR
- Thread Gas male ¾" and 1"
- ATEX Rated Motor ATEX EEx-d 2G (Zone1) IIB T4 IP55 (Gas)
ATEX EEx-d 2D (Zone1) IIB T4 IP65 (Dust)
- Valves Single ball check valve (AISI only), Double ball check valve (PVC only), ceramic and AISI ball valve options available.

4 – 20 mA CONTROL OPTIONS

BD series pumps accept two control options - inverter control or automatic stroke length control. To a 4-20 mA signal. The chart to the left displays the control signal response. The tolerance is ±5%. Please note that this requires a separate 24 V AC power supply and is available for models with 9.3, 10, 12.3, 14, 14.5, 15 and 20 mm stroke lengths only.

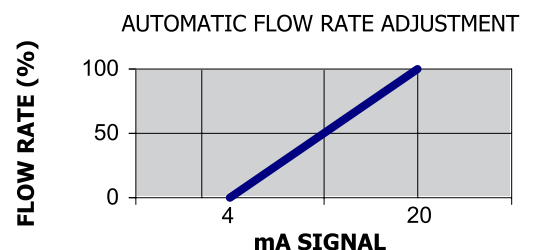

BD Series Motor Driven Diaphragm Pump

DIMENSIONS

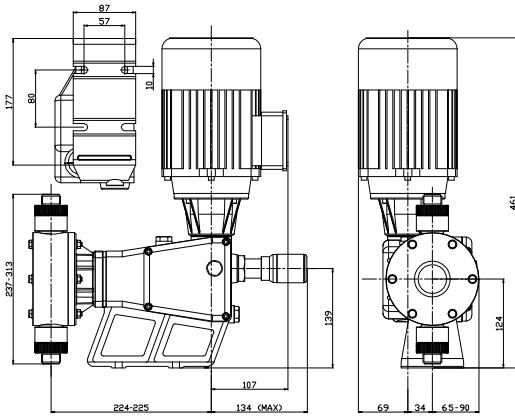

BD motor pump with AISI head

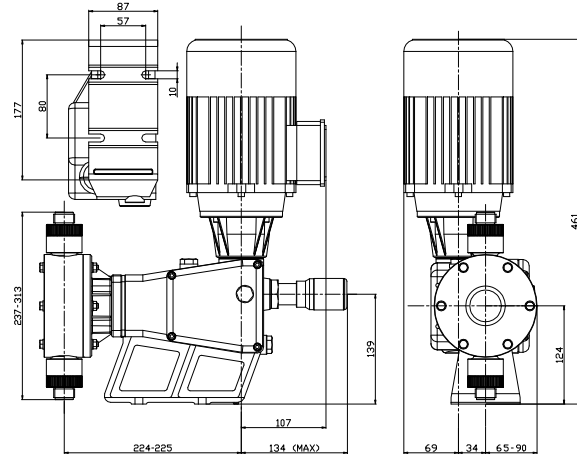

BD motor pump with PVC/PVDF Head

PRODUCT INFORMATION

Code	Flow Rate (L/H)		Pressure (Bar)				Strokes per Minute		Stroke Length (mm)	Motor Output (Kw)	Valve Size
			AISI Pump Head		PVC/PVDF Pump Head						
	50 Hz	60 Hz	50 Hz	60 Hz	50 Hz	60 Hz	50 Hz	60 Hz			
BD0079**00000	79	95	12	11	10	10	60	72	10	0.25	3/4" Gm
BD0135**00000	135	162	10	8	10	8	103	122			
BD0158**00000	158	-	8	-	8	-	120	-			
BD0150**00000	150	180	7.5	6	7.5	6	60	72			1"
BD0257**00000	257	308	6	5	6	5	103	122			
BD0300**00000	300	-	5	-	5	-	120	-			
BD0278**00000	278	334	3.5	3	3.5	3	60	72			
BD0478**00000	478	574	2.5	2	2.5	2	103	122			
BD0535**00000	535	-	2	-	2	-	120	-			
BD0278**00000	278	334	4	3.5	4	3.5	60	72			
BD0478**00600	478	574	3	2.5	3	2.5	103	122			
BD0535**00600	535	-	2.5	-	2.5	-	120	-			

The information within this document may be subject to change without prior notice. All dimensions in mm.

Doc #: **225T01 - 20.0** 2 (2) 01/01/2019

Etatron GB Ltd
 Etatron GB Ltd, Newlin Business Park, Exchange Road, Lincoln LN6 3AB
 Phone: +44 (0)1522 852397
 e-mail: sales@etatron.co.uk – web: www.etatron.co.uk