

B3-V Peristaltic Dosing Pumps

TECHNICAL FEATURES

- *Flow Rate:* Up to 12 L/H
- *Maximum Pressure:* 3 Bar
- *Power Supply:* 90-260v standard; available with optional removable power cable
- *Tubing:* Available in Santoprene®, Silicone, Norprene® or Tygon
- *Flow Rate Adjustment:* 10 – 100%
- *Level Control:* Optional (level probe not supplied)



ACCESSORY KITS

- Suitable for most water treatment applications; includes:
- Standard Kit
- PVC/FPM Injection Valve
 - PP/FPM Foot Filter
 - 2m each of PVC suction & LDPE discharge tubing
- Includes:
- “Brightener” Kit
- Nickel plated brass/FPM Injection Valve
 - SS Foot Filter
 - 2m each of PVC suction & LDPE discharge tubing
- Suitable for use with detergents; includes:
- Detergent Kit
- PP/EPDM Injection Valve with 90° hose nipple
 - SS Foot Filter
 - 2m each of PVC suction & LDPE discharge tubing

DIMENSIONS

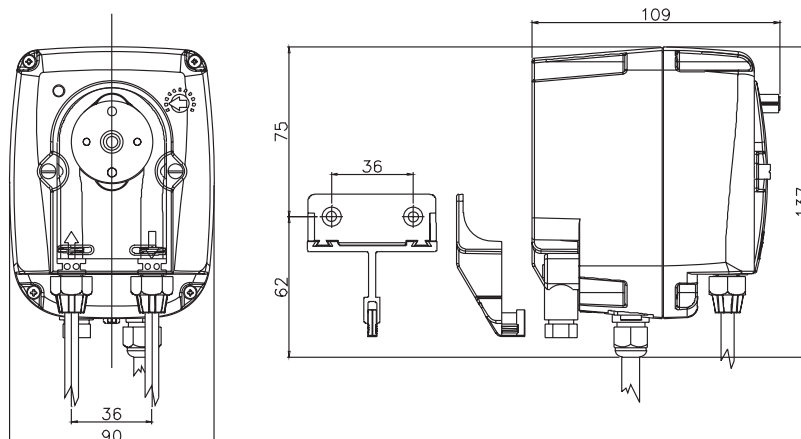

All dimensions are in mm