

AGR-V Mixers

TECHNICAL FEATURES

- Low Speed mixer suitable for Water Treatment
- Available with a range of shaft materials to ensure chemical compatibility (SS304 as standard; options include PP, AISI316 and Abcrite)
- Shaft length from 700 to 1500 mm
- Three phase motors as standard
- Single phase motors available for mixers with shafts of 1000 mm or less
- Motor outputs from 0.18 to 1.5 Kw

DIMENSIONS

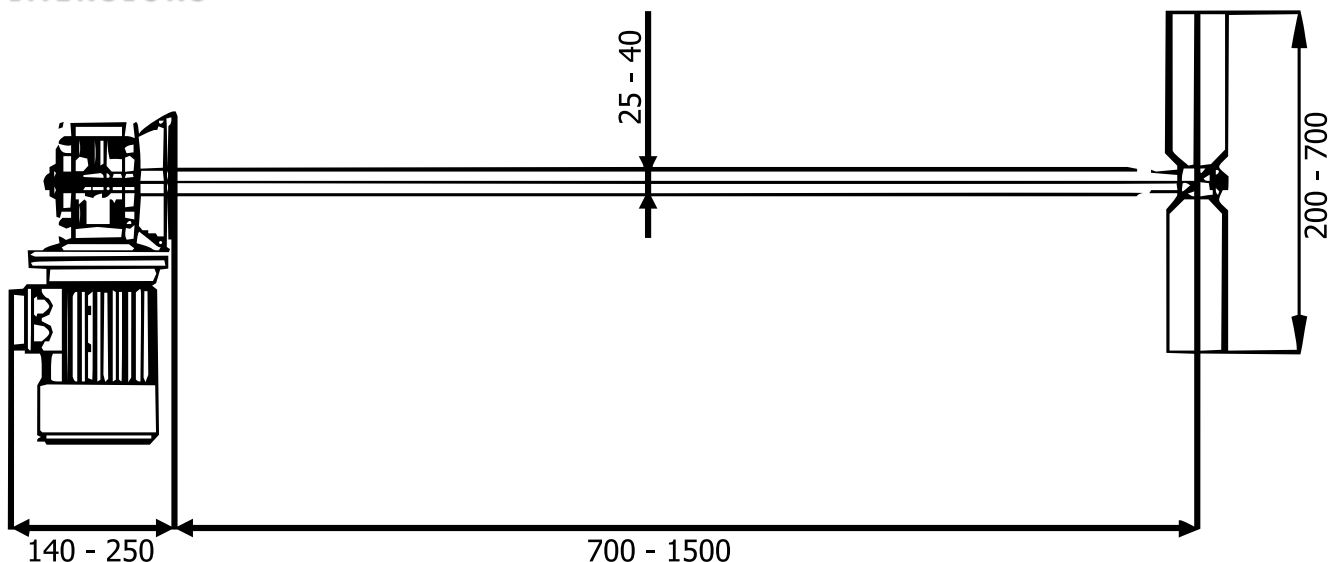

All Dimensions are in mm

AGR-V Mixers are designed for use with a wide range of tanks with a variety of sizes (Shaft lengths of 700 to 1500 mm). With either Single or Three phase motors and a choice of shaft material, the AGR-V Mixers are suitable for an array of dosing systems. The AGR-V Mixers include a support flange for tank mounting allowing for ease of installation.